

CIRCUITS	DIM A	DIM B	DIM C
10	3.20	6.00	4.80
12	4.00	6.80	5.60
14	4.80	7.60	6.40
16	5.60	8.40	7.20
18	6.40	9.20	8.00
20	7.20	10.00	8.80
22	8.00	10.80	9.60
24	8.80	11.60	10.40
26	9.60	12.40	11.20
28	10.40	13.20	12.00
30	11.20	14.00	12.80
32	12.00	14.80	13.60
34	12.80	15.60	14.40
36	13.60	16.40	15.20
38	14.40	17.20	16.00
40	15.20	18.00	16.80
42	16.00	18.80	17.60
44	16.80	19.60	18.40
46	17.60	20.40	19.20
48	18.40	21.20	20.00
50	19.20	22.00	20.80
52	20.00	22.80	21.60
54	20.80	23.60	22.40
56	21.60	24.40	23.20
58	22.40	25.20	24.00
60	23.20	26.00	24.80
62	24.00	26.80	25.60
64	24.80	27.60	26.40
66	25.60	28.40	27.20
68	26.40	29.20	28.00
70	27.20	30.00	28.80
72	28.00	30.80	29.60
74	28.80	31.60	30.40
76	29.60	32.40	31.20
78	30.40	33.20	32.00
80	31.20	34.00	32.80
90	35.20	38.00	36.80
100	39.20	42.00	40.80

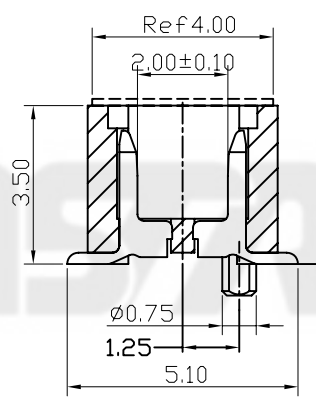
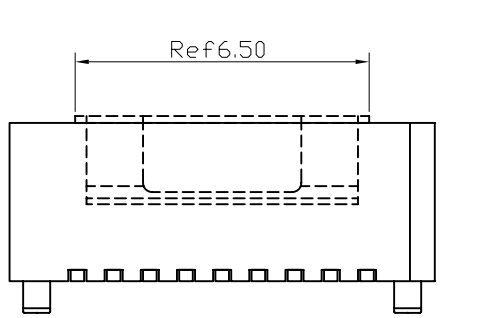
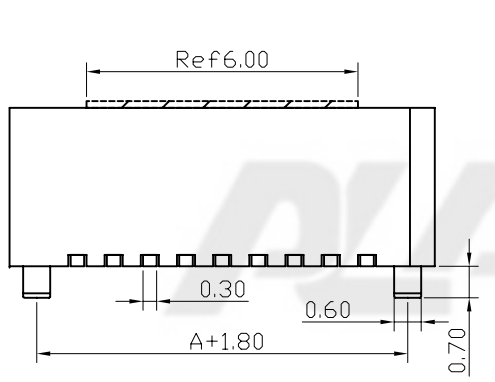
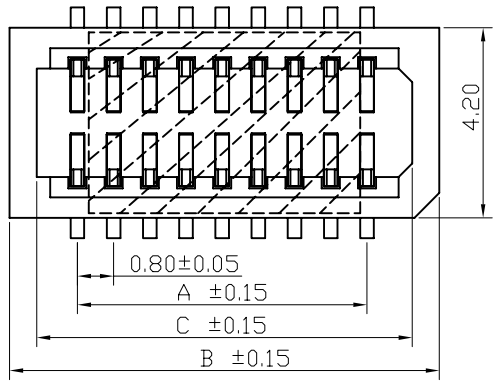

Rev.	ECN Number	Description	Drawn
1	CH11090061	新版發行	XIHONG.LIU_09/16'11

- NOTES: (UNLESS OTHERWISE SPECIFIED)
- ALL DIMENSIONS ARE IN MILLIMETERS.
 - MATERIAL:
HOUSING:UL94 V-0, COLOR:NATURE.
CONTACT:COPPER ALLOYS.
 - DIMENSION SHALL BE INTERPRETED PER "ANSI Y14.5M-1994"
 - CURRENT RATING: 0.5 AMPERE.
 - CONTACT RESISTANCE: 40 m ohms MAX. FOR INITIAL.
 - DIELECTRIC WITHSTANDING VOLTAGE: 500V AC rms. PER ONE MINUTE.
 - INSULATION RESISTANCE: 100 M ohms MIN..
 - HARMFUL MATERIAL SHOULD BE COMPLIANT TO DOC. "EI-0005" STANDARDS.
 - PRODUCT NUMBER MATRIX:
ZIV-XXS1-X-X-*

P/N | | | | |

NULL:TUBE(W/O FILM,MPAD)
B:MPAD+REEL
C:FILM+REEL
E:MPAD+TUBE
K:REEL(W/O FILM,MPAD)
0:W/O Locating peg
1:With Locating peg

Definition	Code
◎Tin plated:	A
◎Gold plated:	
flash B	15μ" F
10μ" E	30μ" J
◎Standard:	B

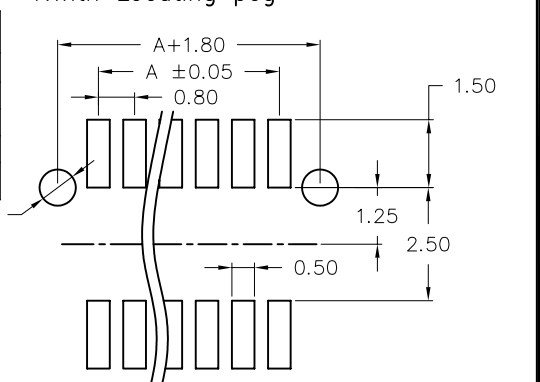

RECOMMENDED PCB LAYOUT
(PCB TOLERANCE ±0.05)



GENERAL TOLERANCE		SCALE	ORIGINAL DRAWN	DATE	DWG. NO.	TITLE	REV.
XX. ±	XXX. ±	1:1	XIHONG.LIU	09/16'11	600-0000-1094	CUSTOMER_DRAWING	1
X. ± 0.30	.XXX ±	UNIT	CHECK	DATE	PARTS NO.(INTENDED USE)		SHEET
.X ± 0.25	X.* ± 3°	MM	---	---	ZIV-XXS1-X-X-*SERIES	1/3	
.XX ± 0.20	.X.* ± 2°	SIZE	APPROVE	DATE			
		A4	LANE.SUN	09/16'11			